



Dash 30



EV Charging Stations

Installation and User Manual



| | | | | | |
|-----------|---|-----------|-----------|--|-----------|
| 1. | Safety and usage instructions | 3 | 8. | Error codes and troubleshooting | 25 |
| 1.1 | Disclaimer | 3 | | | |
| 1.2 | Improper use | 3 | | | |
| 1.3 | Copyright | 3 | | | |
| 1.4 | Trademarks | 3 | | | |
| 1.5 | Languages | 3 | | | |
| 1.6 | Purpose and intended audience | 3 | | | |
| 1.7 | Explanation of text instructions used | 4 | | | |
| 1.8 | General safety | 4 | | | |
| 1.9 | Software and complementary documentation | 4 | | | |
| 1.10 | Operating conditions | 5 | | | |
| 1.11 | Electrical specifications | 5 | | | |
| 2. | Product Overview | 6 | | | |
| 2.1 | Scope of Delivery | 6 | | | |
| 2.2 | Exterior View | 7 | | | |
| 2.3 | Interior View | 8 | | | |
| 2.4 | Identification label | 9 | | | |
| 3. | Installation | 10 | | | |
| 3.1 | Safety announcements | 10 | | | |
| 3.1.1 | Safety symbols | 10 | | | |
| 3.1.2 | Safety risks | 10 | | | |
| 3.2 | Logistics requirements | 11 | | | |
| 3.3 | Assembly and installation requirements | 11 | | | |
| 3.4 | Installation preparation | 13 | | | |
| 3.4.1 | General | 13 | | | |
| 3.4.2 | Site | 13 | | | |
| 3.4.3 | Electrical | 13 | | | |
| 3.5 | Installing the charging station on the pole | 13 | | | |
| 3.6 | Installing the charging station on the wall bracket | 16 | | | |
| 3.7 | Wiring the charging station | 18 | | | |
| 4. | Connectivity | 20 | | | |
| 4.1 | Configuring the charging station | 20 | | | |
| 4.1.1 | Before using the ACE Service Installer | 20 | | | |
| 4.1.2 | Wired network connection | 20 | | | |
| 4.1.3 | Back office management systems | 20 | | | |
| 5. | Usage | 21 | | | |
| 5.1 | User interface | 21 | | | |
| 5.1.1 | Status indicator led button | 21 | | | |
| 5.1.2 | Display | 21 | | | |
| 5.2 | Start charging with RFID card | 21 | | | |
| 5.3 | Stop charging with RFID card | 21 | | | |
| 6. | Maintenance | 23 | | | |
| 6.1 | Check-up Routine | 23 | | | |
| 6.2 | Cleaning | 23 | | | |
| 7. | Disposal | 24 | | | |
| 7.1 | Waste electrical and electronic equipment (WEEE) | 24 | | | |

1. SAFETY AND USAGE INSTRUCTIONS

1.1 Disclaimer

This document has been subjected to rigorous technical review before being published. It is revised at regular intervals, and any modifications and amendments are included in the subsequent issues. Although Alfen has made its best efforts to keep the document as precise and up-to-date as possible, Alfen does not assume any liability for defects and damage which results from the use of the information contained herein.

NOTE

This manual is subject to updates and changes. Errors and omissions excepted.

Any deviation to the products as assembled by Alfen including, but not limited to, customer-specific modifications to the product such as the placement of stickers, SIM cards or the usage of different colors (all referred to as 'Customization') may affect the final product, its experience, appearance, quality and / or lifespan (the Customized Product). Alfen is not liable for any damage to, or caused by, the Customized Product if this damage is caused by this applied Customization.

Alfen shall not be liable in any way, for any kind of damage, and the (B2B) warranty for the product and the accessories shall not apply in the following cases:

- Failure to comply with the instructions in this manual in general and with the operating conditions specifically.
- Improper use.
- External damage.
- Installation, commissioning or faulty repair or maintenance by unqualified persons.
- Failures from the grid or the GPS / GPRS provider.
- Modification or configuration of the product or accessories without the knowledge of Alfen.
- Use of spare parts not approved or manufactured by Alfen.
- The charging station is used outside its operating conditions as stated in this manual.
- Situations have occurred that are beyond the control of Alfen (force majeure).
- Malfunction of an (Open Charge Point Protocol) back office.
- Damage to the electrical vehicle.

1.2 Improper use

Using the charging station is safe when used as intended. Any other use or changes to the charging station are considered improper use and therefore not permitted.

The operator, owner or qualified technician is responsible for any personal injury or material damage arising from improper use.

The Dash 30 is a CCS Charging systems and other adapters or conversion adapters are not allowed to be used.

Any type of cord extension sets are not allowed to be used with Dash 30

Dash 30 is an equipment for locations with non-restricted access.

1.3 Copyright

The reproduction, distribution and utilization of this document, as well as the communication of its contents to other parties without explicit authorization by Alfen N.V. or one of its affiliates, is strictly prohibited. © Alfen N.V.

1.4 Trademarks

Eve®, ICU®, Alfen® are trademarks by Alfen N.V.. Any unauthorized use of the trademarks is therefore illegal.

1.5 Languages

The English version of this document is the original source. Documents in other languages are translations of this source.

1.6 Purpose and intended audience

This manual applies to the Alfen Dash 30 (in this document also indicated as "charging station") produced by Alfen ICU B.V., Hefbrugweg 79, 1332 AM Almere, the Netherlands, reg. no. 39037364 ("Alfen"). The Dash 30 is intended exclusively for charging electric vehicles and, when installed correctly, may be used by untrained individuals. Follow this manual to install the charging station correctly.

Installation and maintenance of this charging station may only be performed by a qualified electrician. It is essential that the qualified technician has:

- Expertise on all relevant general and specific rules regarding safety and incident prevention
- Comprehensive knowledge of applicable electrical regulations.
- The ability to identify risks and avoid potential hazards
- Received and read these installation and operation instructions

NOTE

This charging station is a Mode 4 - DC EV Supply equipment.

1. SAFETY AND USAGE INSTRUCTIONS

1.7 Explanation of text instructions used

Safety warnings and precautions are indicated in this document as follows:

DANGER

“Danger” is the signal word that indicates an imminently hazardous situation that, if not avoided, will result in death or serious injury.

WARNING

“Warning” is the signal word that indicates a potentially hazardous situation that, if not avoided, could result in death or serious injury.

CAUTION

“Caution” is the signal word that indicates a potentially hazardous situation that, if not avoided, could result in minor or moderate injury.

NOTE

“Note” is the signal word that provides additional information or information on possible product damage.

1.8 General safety

Follow the stated safety aspects when operating the charging station:

DANGER

Risk of injuries, explosion or fire. Do not use the charging station in the vicinity of explosive or highly flammable substances.

DANGER

Risk of electrocution. Do not use the charging station if it is partially submerged in water.

DANGER

Risk of injury and electrocution. Do not use the charging station if it is damaged or plugs and cables are defective. Contact the charge point operator to repair the defects immediately.

DANGER

Risk of injury and electrocution. Keep away children or individuals who are not able to assess the risks associated with using this product.

More extensive safety information is available in the relevant sections of this document.

1.9 Software and complementary documentation

The charging station uses the firmware version 2.0 at the time of writing.

NOTE

The most current firmware version is downloaded and installed automatically when connected to the network

NOTE

It is possible to request a printed copy of this manual in your language by Alfen at any time. Refer to the contact information for your request.

Under the following links you can obtain detailed information regarding the charging station.

YouTube channel



[Alfen - Power to adapt](#)

Providing installation, service and information videos.

Data sheet



[Datasheet](#)

Providing detailed information on technical features and equipment.

Knowledge Base



[Knowledge Base](#)

Providing FAQ (frequently asked questions) section, service and procedure instructions.

1. SAFETY AND USAGE INSTRUCTIONS

Firmware & Error code list



[Error codes and troubleshooting](#)

Provides information on current firmware and list of error messages displayed on the charging station.

Declaration of Conformity



[Declaration of Conformity](#)

Training for Alfen charging stations



[Trainings charging stations equipment](#)

Classroom trainings provided by Alfen.

Warranty



[B2B Warranty](#)

Provides the applicable Terms & Conditions of the Alfen B2B Warranty

1.10 Operating conditions

| | |
|-----------------------------------|----------------|
| Operating temperature | -25°C to +50°C |
| Relative atmospheric humidity | 5% to 95% |
| Electrical safety class | Class I |
| Degree of protection | IP55 |
| IK protection (mechanical impact) | IK10 |

NOTE

The operating temperature stated is under the following conditions:

- The influence of direct solar radiation on the charging station is excluded.
- The influence of Customizations applied on the charging station is excluded.

1.11 Electrical specifications

Power Input

| | |
|---------------|---|
| Input voltage | 3P+ N (400 V/230 V +/- 10%), 50 Hz +/- 5% |
| Mains type | TN-C, TN-S, TN-C-S, TT |
| Input current | ≤ 3 x 50 A RMS (50Arms Nominal per phase) |
| Power Factor | Rated output Load ≥ 0.99 |
| Current THD | < 5% @full load |
| Efficiency | > 95% |

Power output

| | |
|----------------|--|
| Output voltage | 200 - 910 V DC |
| Output current | ≤ 80 A DC (certified) (≤ 91 A DC tested during certification) |
| Output power | 30 kW |

Standby

| | |
|-------------|--------|
| Consumption | ≤ 40 W |
|-------------|--------|

2. PRODUCT OVERVIEW

2.1 Scope of Delivery

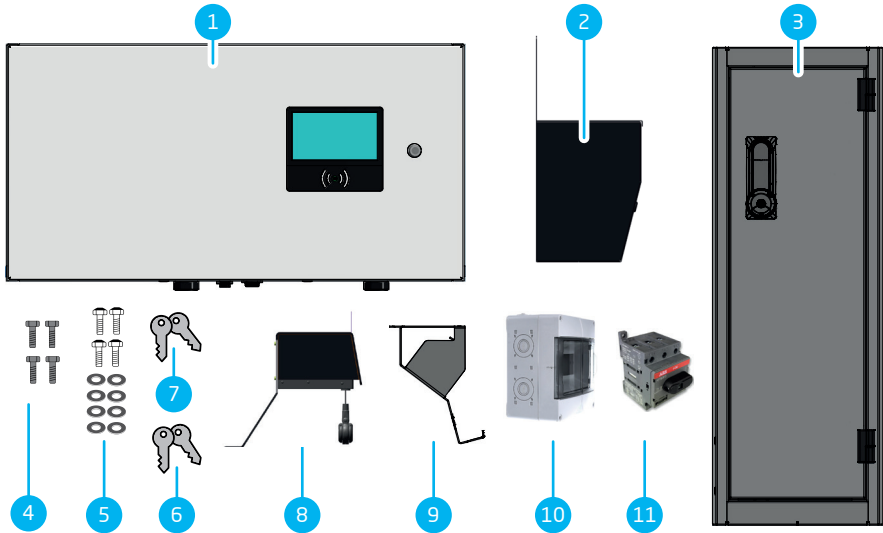

Figure 2.1: Scope of delivery items

| Nr. | Description | Quantity |
|-----|---|----------|
| 1 | Charging station | 1 |
| 2 | Wall bracket (excludes pole, see notes) | 1 |
| 3 | Pole (excludes wall bracket, see notes) | 1 |
| 4 | M10x20 bolts | 4 |
| 5 | Safety screws & washers | 9 each |
| 6 | Pole keys / wall bracket keys | 2 |
| 7 | Charging station keys | 2 |
| 8 | Retractor unit | 1 |
| 9 | Plug holder | 1 |
| 10 | Switch box | 1 |
| 11 | Main switch | 1 |

NOTE

When you buy this charging station, you must choose either a pole or a wall bracket for your installation. Your choice will affect the total cost of the charging station.

2.2 Exterior View

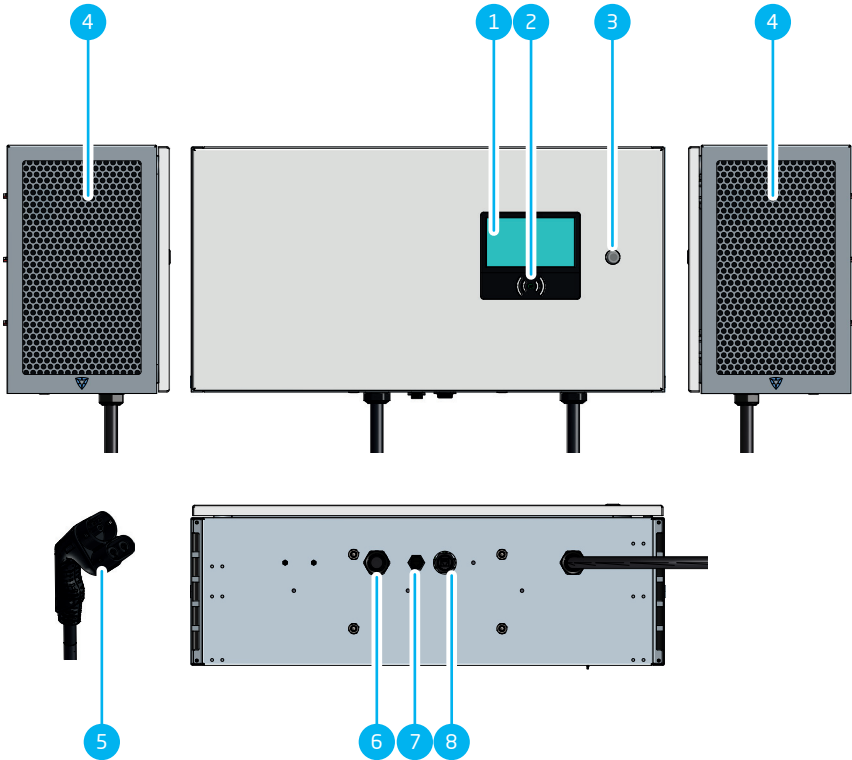

Figure 2.2: External components view

| Nr. | Description |
|-----|--------------------------------|
| 1 | Display |
| 2 | RFID reader |
| 3 | Button (configurable function) |
| 4 | Side panels |
| 5 | EV charging cable (CCS2) |
| 6 | Input cable gland |
| 7 | Data cable entry |
| 8 | Energy meter cable entry |

2. PRODUCT OVERVIEW

2.3 Interior View

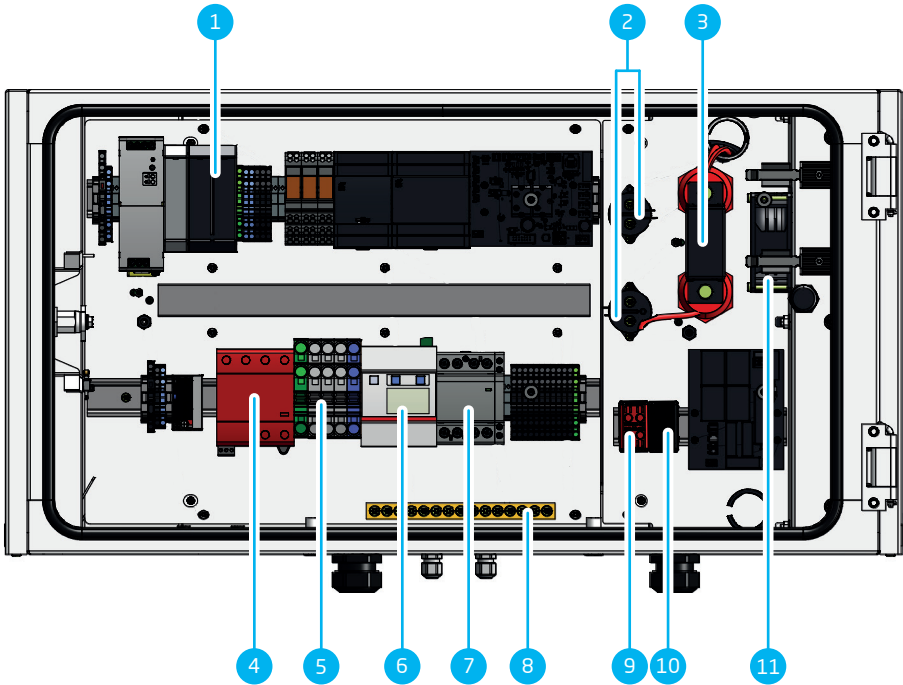

Figure 2.3: Overview internal components (frame)

| Nr. | Description |
|-----|---|
| 1 | SECC module (Supply Equipment Communication Controller) |
| 2 | DC contactors |
| 3 | DC fuse |
| 4 | Surge protection device (SPD) |
| 5 | Terminal box |
| 6 | Energy meter |
| 7 | AC contactors |
| 8 | Earthing bar |
| 9 | Output DC + |
| 10 | Output DC - |
| 11 | Fans |

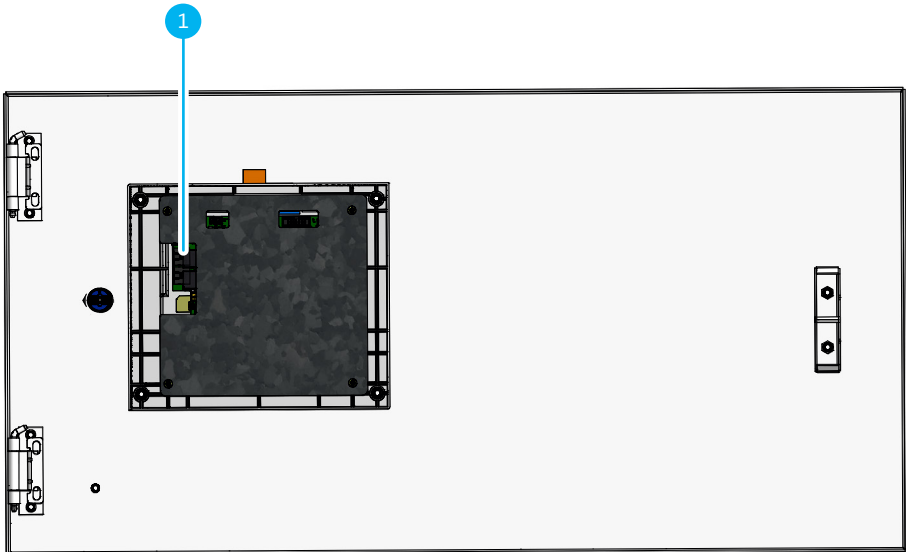

Figure 2.4: Overview internal components (door)

| Nr. | Description |
|-----|-------------------|
| 1 | Data cable socket |

2.4 Identification label

The identification label shows the following information:



| No. | Description |
|-----|---|
| 4 | Object number (unique number per charging station) |
| 5 | Production date |
| 6 | Technical specifications (such as the number of phases, maximum charging current and voltage) |

| No. | Description |
|-----|---|
| 1 | OCPP charge point model name (consisting of the platform name and the last five digits of the article number) |
| 2 | Type / Article number |
| 3 | Product name |

NOTE

When contacting your charge point supplier / operator, always have your type / article number and object number available to facilitate quick support.

3. INSTALLATION

3.1 Safety announcements

3.1.1 Safety symbols

The following warning pictograms and labels are attached to (parts of) the charging station:



3.1.2 Safety risks

At any time during the installation of the product, make sure to observe the following indications

⚠ DANGER

Always wait at least 30 seconds after switching off the system, before opening the charging station door or touching any of its electrical components.

⚠ DANGER

Risk of injury and electrocution. Installation, (de)commissioning and maintenance of the charging station may only be performed by a qualified electrician.

⚠ DANGER

Risk of injury and electrocution. Installing the charging station incorrectly may result in fatal injury! When working with electricity, failure to comply with relevant regulations can lead to dangerous and life-threatening situations.

⚠ DANGER

Risk of electrocution. The electrical system must be disconnected from every power source before performing any installation or maintenance work!

⚠ DANGER

Risk of injury and electrocution. The charging station contains electrical components that still contain a charge after being disconnected from the system. Always test with proper equipment that there is no residual current before starting to work.

⚠ WARNING

Risk of injuries, explosion or fire. Never install in a potentially explosive atmosphere.

⚠ WARNING

Risk of injury and electrocution. Installation work may not be carried out during rain or if the air humidity exceeds 95%.

⚠ WARNING

Risk of electrocution. Never install in areas prone to flooding without implementing compensatory measures.

⚠ WARNING

Risk of injury and electrocution. The installation must be performed by a qualified electrician who has read this manual and will execute the installation in accordance with the IEC 60364 (Electrical Installations for Buildings) standard.

⚠ WARNING

Risk of damage or electrocution. Local conditions may affect the installation requirements. Your installation must comply with the standards and regulations of the location (country) where it is installed.

⚠ WARNING

Risk of damage or electrocution. A charging station must always be installed on separate power circuit.

! CAUTION

Risk of injury and damage. The installer is always responsible for choosing the correct cable diameter and complying with the relevant standards and legislation.

! CAUTION

Risk of injury and damage. The installation and cables should be installed to match the maximum charging current to the input of the charging station. This should assume continuous load.

! CAUTION

Risk of injury and damage. Mechanical impact and/or collisions might cause damage to the equipment. Protect Alfen products installed in public areas and car park sites.

! CAUTION

Risk of damage. Adapters or conversion adapters are not allowed to be used.

3.2 Logistics requirements

Transportation of the charging station, must be carried out in such a way as to protect the components from major impacts, humidity, and vibrations.

When loading, lifting, storing and delivering products, avoid sudden or fast movements. These could harm both the charging station and the handler of the charging station.

In case the charging station was inadequately handled during transportation, a thorough inspection of the charging station integrity must be performed to certify that no damage was caused.

Do not leave the packaged charging station in open air and/or exposed to the elements.

Any machinery or tools used for lifting the charging station must be able to withstand its weight. The charging station is not equipped with specific lifting tools.

Due to the weight of the charging station, personnel for transportation, handling and lifting must be considered in accordance with the requirements of local regulations.

Consider local regulations and law for transporting, handling and lifting the charging station.

3.3 Assembly and installation requirements

The installer and charge point operator must be instructed correctly. The installer and charge point operator must therefore read and follow the technical instructions contained in the installation manual and in the other documentation of the charging station.

The charging station must not be used if any operational fault is identified.

Installation, commissioning and maintenance of the charging station must be performed by qualified electricians who are responsible for complying with existing standards and local installation regulations.

When selecting a location to install the charging station, the following criteria must be met:

- Always fully comply with local technical requirements and safety regulations.
- An on-site connection has been prepared that complies with the specifications of the charging station.
- The installation site must have a levelled and solid foundation or, if the charging station is installed into the ground, preparing the foundation is part of the installation process.
- The installation site is provided with a solid right angled wall, see height recommendations in the following paragraph.

Please refer to the following table for safety options and cable cross-sections advised.

Power supply cable: minimum advised cable cross-section (based on assumed max. 100 m input cable from transformer):

- 3-phase 4 wire 30 KW charging, 63 A per phase; 5x16 mm² cables

Recommended Short circuit protection:

With circuit breakers:

- 3-phase 4 wire 63 A (45 KVA): 1x63 A, 4 pole, type B MCB

Recommended earth leakage protection (possibly in combination with circuit breaker):

- Residual current device: 30 mA AC and 6 mA DC, 63 A 4 pole Type B RCD

3. INSTALLATION

Nominal input voltage:

- VL₁-N: 230 V (+/-10 %)
- VL₂-N: 230 V (+/-10 %)
- VL₃-N: 230 V (+/-10 %)
- VL₁-L₂: 400 V (+/-10 %)
- VL₁-L₃: 400 V (+/-10 %)
- VL₂-L₃: 400 V (+/-10 %)
- VPE-N: ≈ 0 V

Nominal frequency: 50 Hz (+/-5 %)

Ethernet Connection:

- Shielded ethernet connector. Maximum allowed cable length is 30 m.

List of the tools needed:

Table 1: Required tools

| Tool | Notes |
|---------------------------------------|-----------------|
| T20 screwdriver | |
| Wago operating tool | |
| Pump pliers | For the swivels |
| Combination Wrench nr.17 | |
| Torque wrench (20-50 Nm) | |
| Ruler | |
| Cable stripper | |
| 6 mm Flat head or slotted screwdriver | |
| Hex wrench 7 mm | |
| Wire cutter | |
| Data cable assembly tools | |
| Voltage tester Dupsol | |
| Power Drill | |
| Spirit level tool | |
| Marker | |

Table 1: Required tools

| Tool | Notes |
|---------------------------------|---|
| Multimeter for Ground Measuring | |
| Insulation tape PE | In the event that the installer must create a ground connection using the insulated wires |

List of the materials needed:

Table 2: Required materials

| Tool | Quantity | Notes |
|-------------------------|----------|--|
| Ground Cable | | Conductive cable used to establish a connection between the DC charger and the ground, ensuring electrical safety. |
| Wall Plugs | | Anchor points for securing bolts or screws into walls, providing stability for mounted components. |
| Ring Terminal | | Connects electrical wires to bolts or screws securely, providing a reliable electrical connection. |
| Drill Bit | | Used with the power drill for drilling holes in walls or surfaces during installation. |
| M10 Bolts | 4 | |
| Power cable | | Flexible cables make for an easier installation |
| MCB | | |
| Ethernet cable cat 5e/6 | | |
| RJ-11 connectors | | |
| RJ-45 connectors | | |
| Ferrules | | |

3.4 Installation preparation

3.4.1 General

- Read this installation manual before you begin the installation process.
- Check the scope of delivery and required parts.
- Download the data sheet on alfen.com for product specific information.

3.4.2 Site

- View the site and determine the installation location.
- The charging station is not in direct sunlight.
- Make sure the following clearance requirements are met:
 - Clear from any objects on top of the device: 0.6 m
 - Clear from any objects right side of the device: 1 m
 - Clear from any objects left side of the device: 1 m
 - Clear from any objects front side of the device: 1 m

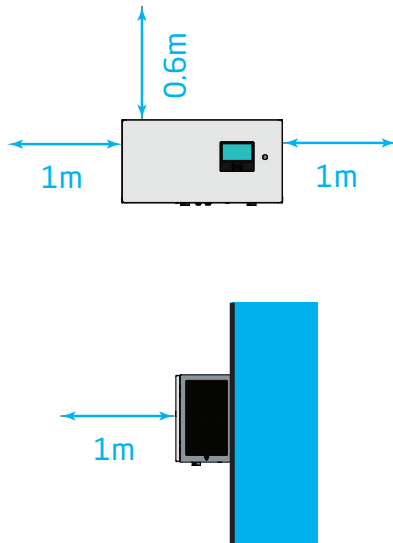

Figure 3.1: Clearance requirements

3.4.3 Electrical

⚠ WARNING

In each type of grid, the installer is responsible for the safe installation and calculation of the protection.

- Recommended grid connection upstream:
 - MCB 63 A char B
 - RCD 63 A, 30 mA, type B
 - Max. let-through peak $I_{pk}=6.5$ kA
 - $I_{prospective}=10$ kA rms
 - Max. let-through energy $I^2t = 90,000$ A²s

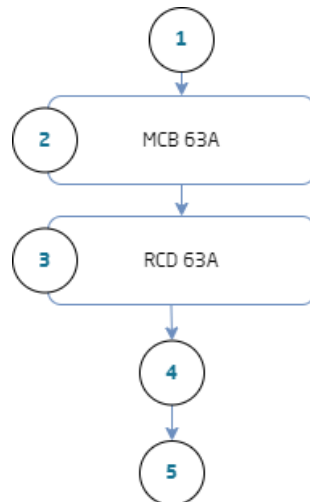

Figure 3.2: Grid box Connection scheme

No. Description

- | | |
|---|--|
| 1 | Grid connection box in |
| 2 | MCB 63 A, char B, max peak let-through 10 kA |
| 3 | RCD 63 A, 30 mA, type B. Coordinated with the selected MCB |
| 4 | Grid connection box out |
| 5 | Switch box of the charging station (located inside the pole or the wall bracket) |

3.5 Installing the charging station on the pole

3. INSTALLATION

NOTE

It is advised to have at least two technicians work on the installation.

If you choose for a pole installation:

1. Fix the pole on a prepared concrete base with a torque wrench fixed at 45 Nm.
2. Mount and fasten the retractor plate with four M6 bolts on the top right side of the charging station and the retractor unit with four M6 bolts to the retractor plate

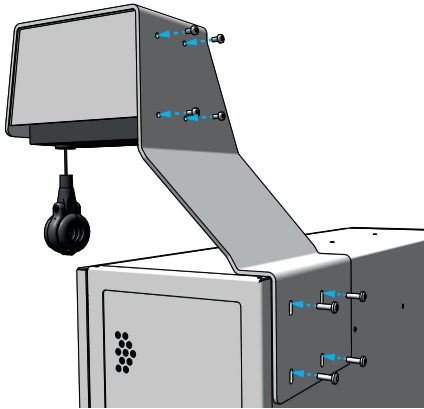

3. Unlock and open the pole's door.

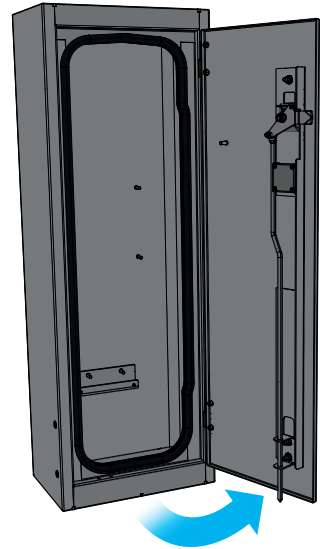

4.

NOTE

The charging station weights more than 50 kg. Make use of an electric lifter to put the charging station in position.

Lift the charging station and carefully place it on top of the pole. Make sure to align the bolts sockets of the charging station with the bolt sockets of the pole.

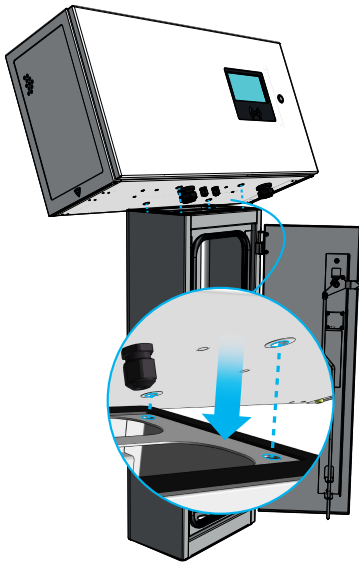

5. Fasten the charging station on the pole, using M10 bolts in the underneath sockets.

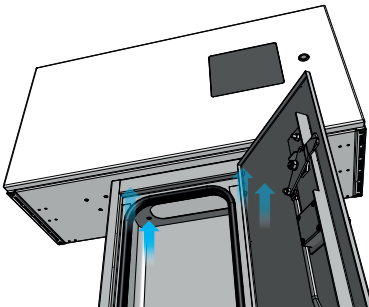

6. Tighten the bolts until the charging station is well secured. Make sure all the bolts are tightened at 42 Nm.
7. Mount and fasten the plug holder with three M6 screws to the bottom right side of charging station.

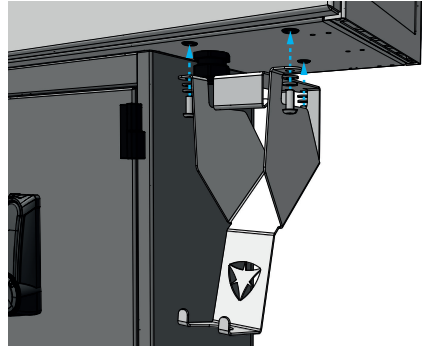

8. Mount the cable clamp of the retractor on the cable at about 2400 mm from the cable plug.
9. Your pole installation is now complete.

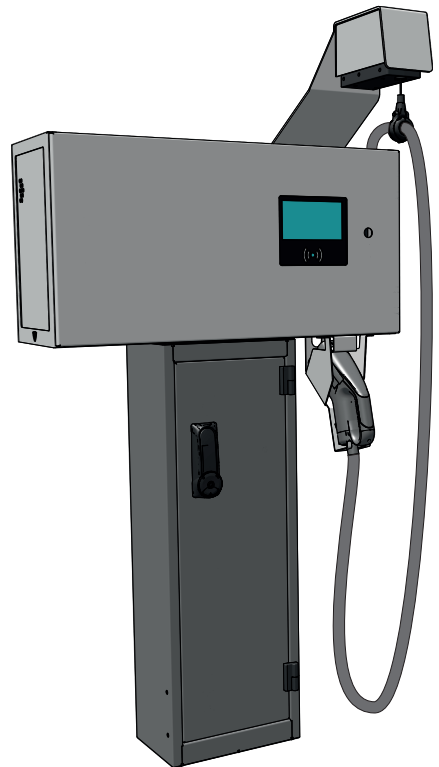

3. INSTALLATION

EN

3.6 Installing the charging station on the wall bracket

NOTE

It is advised to wall mount the charging station on a flat surface.

NOTE

It is advised to have 3 technicians work on the installation.

NOTE

The device weights more than 50 kg, make use of a lifter to put the device in position.

If you choose to install the product on a wall:

1. Align the top of the wall bracket at 950 mm from the ground, and drill the required holes

NOTE

Drill size is 12. Use a bit extender for ease of access.

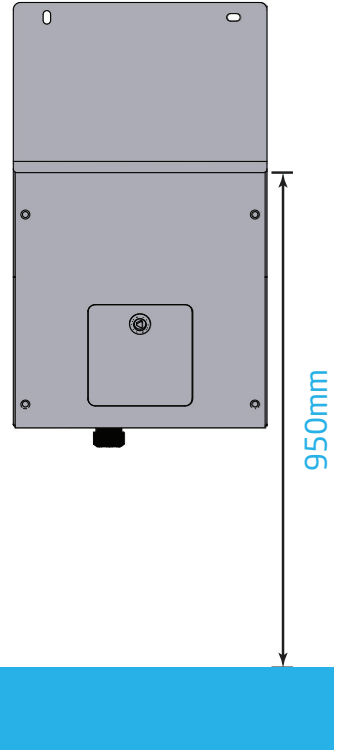

2. Fasten the wall bracket to the wall.

3. INSTALLATION

EN

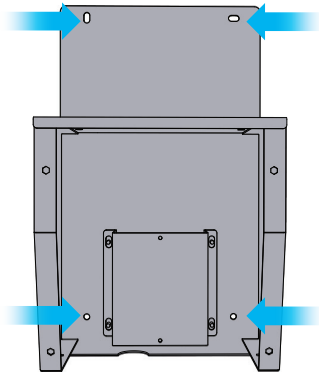

3. Use a spirit level check whether the wall bracket is straight.
4. Install the adapter plate for the switch on the back plate of the wall bracket, if not present.
5. Mount and fasten the retractor plate with four M6 bolts on the top right side of the charging station and the retractor unit with four M6 bolts to the retractor plate

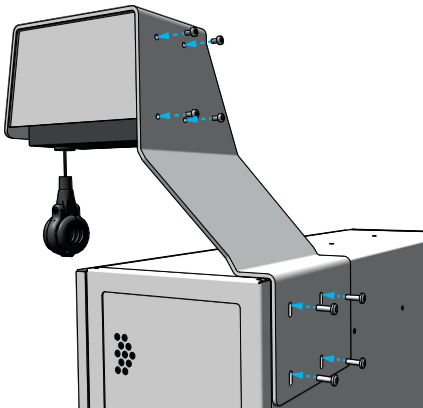

6. Place the charging station on top of the bracket, and fasten the charging station on the wall bracket, using M10 bolts in the underneath sockets.

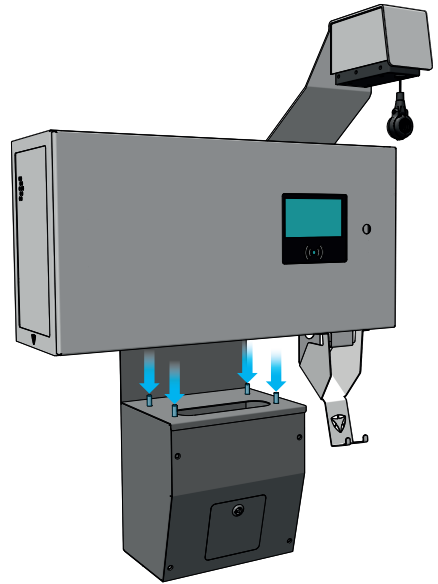

7. Tighten the bolts until the charging station is well secured in place. Make sure the bolts are tightened at 42 Nm.
8. Mount and fasten the plug holder with three M6 screws to the right side of charging station box.

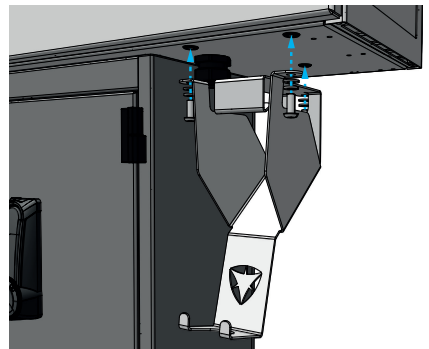

9. Mount the cable clamp of the retractor on the cable at about 2400 mm from the cable plug.
10. Your wall bracket installation is now complete.

3. INSTALLATION

EN

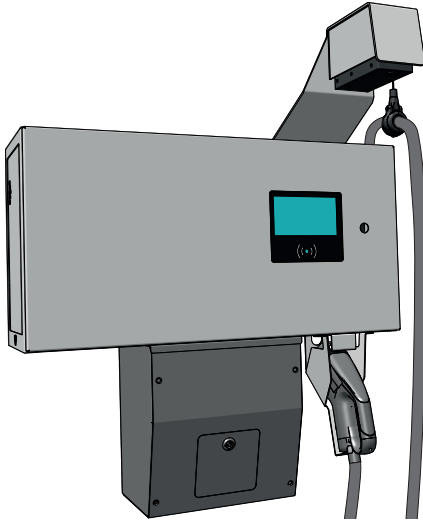

3. Determine the length of the feeder cables going in and out of the main switch box, and strip them accordingly.
4. Wire the feeder cables in and out of the main switch. To facilitate the process, you can unfasten the switch box, and then install and wire the main switch.
5. Set the wire safety at the bottom of the cabinet if needed.
6. Unscrew the two torx 20 bolts located at the bottom left of the charging station.

3.7 Wiring the charging station

DANGER

Always wait at least 30 seconds after switching off the system, before opening the charging station door or touching any of its electrical components.

DANGER

Risk of electrocution. The electrical system must be disconnected from every power source before performing any installation or maintenance work!

DANGER

Risk of injury and electrocution. The charging station contains electrical components that still contain a charge after being disconnected from the system. Always test with proper equipment that there is no residual current before starting to work.

To wire the charging station:

1. Install the main switch box into the pole cabinet or wall bracket cabinet.
2. Determine the feeder cable size and change the cable gland on the charging station accordingly. The default size of the cable gland is 16 mm². If the incoming wire is 10 mm², change the cable gland accordingly.

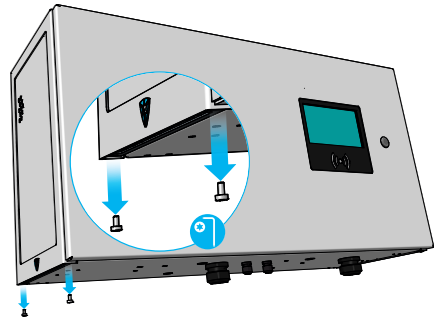
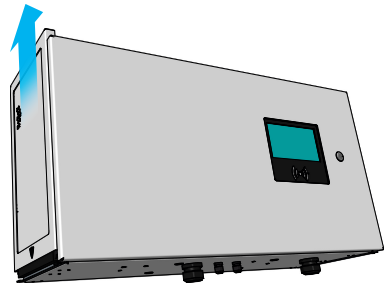

Figure 3.3: Lower mounting bolts

7. Slide the side panel up, to remove it.



8. **NOTE**

Make sure the wiring going into the front panel doesn't get stretched while opening the charging station.

Insert the charging station key provided with the charging station and turn it anti-clockwise to open the front door.

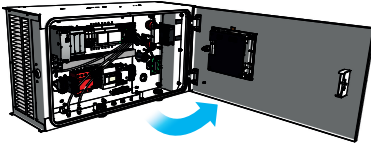

9. Loosen the cable gland and then insert power cable through the cable gland at the bottom. Make sure to open the cable gland before pulling the wire through.

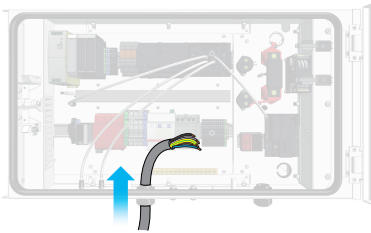

10. Prepare the power cable and the wires, setting up the wire caps.

! CAUTION

Make sure the power cables used are capable of bearing the current load

11. Link the wires to the terminal box.

i NOTE

The earthing wire must be connected to the earthing bar, see image

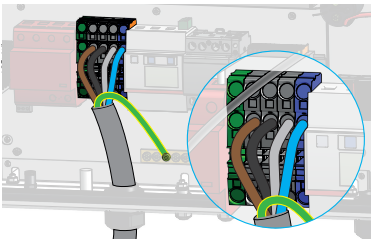

12. Optional: Insert the data cable through the cable entry at the bottom and connect it to the FP100 module located inside the front panel.

! WARNING

If you do not make use of data cables, seal the 2 holes for data cables at the bottom of the charging station.

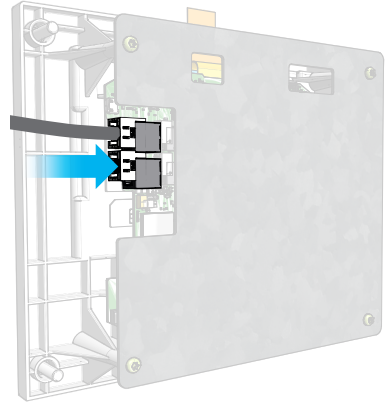

13. Close the door, and turn the key clockwise to lock it.

14. Align the side panel to the two pins and slide it down until the top side is levelled with the top side of the charging station.

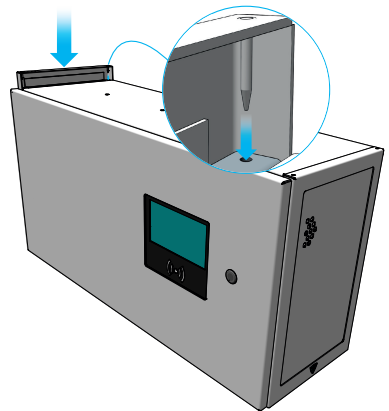

15. Fasten the tx20 bolts of the side panels.

4. CONNECTIVITY

4.1 Configuring the charging station

4.1.1 Before using the ACE Service Installer

1. Download the ACE Service Installer from the Alfen website to your laptop:

<https://alfen.com/en-gb/search-downloads>

2. Request an account at this e-mail address: ace.aftersales@alfen.com.

NOTE

It may take some days until you receive the login-data.

3. If you have the ACE Service Installer installed, make sure you have the latest version. If updates are available, you will be asked to update when you log in.
4. Make sure the firewall settings on your device are not blocking the ACE Service Installer.

4.1.2 Wired network connection

How to establish a wired network connection by connecting the charging station to your device using an UTP (Ethernet) cable:

The minimum requirement is a shielded CAT5 S/UTP (Ethernet) cable

NOTE

For the use of a smartphone or tablet an adapter such as a USB-C to Ethernet or Lightning to Ethernet is required.

1. Log into the ACE Service Installer.
2. Connect the RJ-45 (Ethernet) directly to the charging station, or the router the charging station is connected to.
3. Select your charging station from the list in the ACE Service Installer.
4. Enter the provided password.
The network connection has now been established. Via the ACE Service Installer you can configure the settings
5. After finishing the configuration, hand over the card with password (recovery) information to the customer.

4.1.3 Back office management systems

If additional services by a back-office provider have been purchased, the charging station has been configured ex-factory to connect to the selected back-office management system.

NOTE

A connection with a backoffice management system can only be established if arrangements with the supplier of this system have been made. The service of third parties is not provided by Alfen.

NOTE

If the charging station is set to connect with a backoffice management system, it will do so directly and automatically.

NOTE

If a mobile communication (SIM card) Internet connection has been purchased, the charging station is already equipped with a SIM card and will automatically connect, once the charging station is being commissioned.

5.1 User interface

5.1.1 Status indicator led button



Blue Flashing: Charging



Blue: Charging terminated



Green: The charging station is available for charging



Green Flashing: Vehicle is plugged in, RFID card has been swiped correctly (if needed)



Red: The charging station cannot charge



Flashing Red: The charging station has an error but has no safety issues and can charge



5.1.2 Display

Depending on the status of the charging station, the display will show different information.

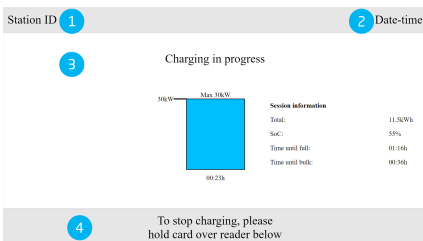

Figure 5.1: Display while charging in progress

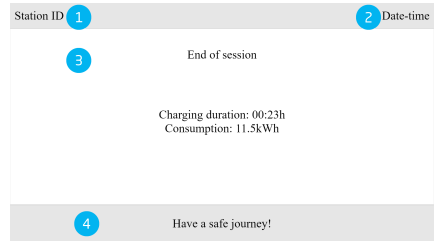

Figure 5.2: Display when charging session ends

| No. | Description |
|-----|---------------------------------------|
| 1 | Station Unique identifier (ID) |
| 2 | Current Date-Time on the Charge Point |
| 3 | Status information |
| 4 | Instruction information |

5.2 Start charging with RFID card

| No. | Description |
|-----|--|
| 1 | Scan the RFID card on the charging stations RFID reader |
| 2 | Pick up the charging cable gun from the charging station |
| 3 | Plug the charging cable into the car |
| 4 | Charging in progress |

NOTE

If charging does not initialize, scan the RFID card to stop charging or press the button on the EV socket to unlock the charging cable. Afterwards, reconnect the charging cable to the EV.

5.3 Stop charging with RFID card

| No. | Description |
|-----|---|
| 1 | Scan the RFID card on the charging stations RFID reader |
| 2 | Remove the charging cable from the car |

5. USAGE

| No. | Description |
|-----|--------------------------------------|
| 3 | Place the cable gun back |
| 4 | You can now leave the charging place |

6.1 Check-up Routine

To ensure the charging station is kept in a good state of use, please perform periodical maintenance as hereby indicated.

⚠ DANGER

Always wait at least 30 seconds after switching off the system, before opening the charging station door or touching any of its electrical components.

⚠ CAUTION

If the upstream MCB trips due to a short-circuit, do not turn the charging station on, and call Alfen for service

⚠ DANGER

Risk of electrocution. The electrical system must be disconnected from every power source before performing any installation or maintenance work!

⚠ DANGER

Risk of injury and electrocution. The charging station contains electrical components that still contain a charge after being disconnected from the system. Always test with proper equipment that there is no residual current before starting to work.

⚠ CAUTION

Maintenance must be performed only by a qualified technician

- Keep the space around the charging station clear and ventilated
- Take care of any status note shown on the display
- Replace air filters every 6 months
- Check for signs of liquid infiltration, and if any is found, disconnect the charging station immediately from the system
- Check for damages to the connector and the CCS2 plug, and if any is found, discontinue the charging station immediately

6.2 Cleaning

We recommend to clean the charging station periodically, to keep the charging station in good look and state. While cleaning the charging station, observe the following notes:

⚠ CAUTION

Do not use a pressure washer to clean the charging station.

💡 NOTE

Wipe the outside shell and casing with a non-abrasive damp cloth.

💡 NOTE

Do not use harsh cleaning agents, e.g. acetone, benzene, etc.

7. DISPOSAL

7.1 Waste electrical and electronic equipment (WEEE)



Electrical and electronic equipment contains materials, components and substances that may be hazardous and present a risk to human health and the environment if not handled correctly.

Equipment marked with the illustrated crossed out wheeled bin is electrical and electronic equipment. The crossed out wheeled bin indicates that this waste must be collected separately and must not be discarded together with household waste.

Refer to your local authority for collection schemes under which residents can dispose waste electrical and electronic equipment at a recycling center or other collection points.

8. ERROR CODES AND TROUBLESHOOTING

| Code | Error message displayed | Possible cause | Possible solutions |
|------|--|----------------|--------------------------|
| 418 | The charge point is experiencing technical issues. To remove this message, log in to device. | | Contact CPO/service team |

Contact

Alfen ICU B.V.
Hefbrugweg 79
1332 AM Almere
The Netherlands

P.O. box 1042
1300 BA Almere
The Netherlands

Alfen Knowledge Base: knowledge.alfen.com
Alfen Service Portal: aftersales.alfen.com
Tel. Service: +31 (0)36 54 93 402
Website: alfen.com

